



**RB200 SERIES**  
**SILICON BRIDGE RECTIFIERS**

**FEATURES**

- This Series Is UL recognized under the file number E135627.
- Plastic material used carries Underwriters Laboratory recognition.
- High case dielectric strength.
- Exceeds environmental standards of MIL-STD-19500.
- Ideal for printed circuit board.
- High temperature soldering guaranteed : 265°C/10 seconds/.375" ( 9.5mm) lead length/5 lbs., ( 2.3kg ) tension

**MECHANICAL DATA**

Case : Reliable low cost construction utilizing molded plastic technique  
 Terminals : Leads solderable per MIL-STD-202, Method 208  
 Mounting position : Any  
 Weight : 1.4 grams.

**VOLTAGE RANGE**  
**50 to 100 Volts**  
**CURRENT**  
**2.0 Amperes**

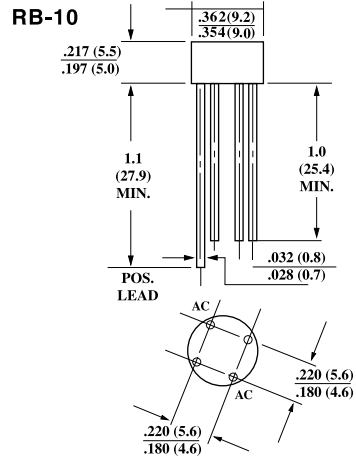

**Dimensions in inches and (millimeters)**

**MAXIMUM RATINGS AND ELECTRICAL CHARACTERISTICS**

Ratings at 25 °C ambient temperature unless otherwise specified. Single phase, half wave, 60Hz, resistive or inductive load. For capacitive load, derate current by 20%.

<b>RATINGS</b>	<b>RB200</b>	<b>RB201</b>	<b>RB202</b>	<b>RB204</b>	<b>RB206</b>	<b>RB208</b>	<b>RB2010</b>	<b>Units</b>
Maximum Recurrent Peak Reverse Voltage	50	100	200	400	600	800	1000	V
Maximum RMS voltage	35	70	140	280	420	560	700	V
Maximum DC Blocking Voltage	50	100	200	400	600	800	1000	V
Maximum Average Forward Rectified output current .375" ( 9.5mm ) Lead Lengths at T <sub>A</sub> = 25°C	2.0							A
Peak Forward Surge Current , 8.3ms single half sine-wave superimposed on rated Load ( JEDEC method )	50							A
I <sup>2</sup> t Rating for Fusing ( t < 8.3ms )	15.0							A <sup>2</sup> S
Maximum Forward Voltage Drop Per Element at 1.0A	1.0							V
Maximum DC Reverse Current, T <sub>A</sub> = 25°C at Rated DC Blocking Voltage T <sub>A</sub> = 100°C	10.0							µA
Typical Junction Capacitance per Bridge Element (Note1)	1.0							mA
Typical Junction Capacitance per Bridge Element (Note1)	30							pF
Operating Temperature Range T <sub>J</sub>	-55 to + 125							°C
Storage Temperature Range T <sub>STG</sub>	-55 to + 150							°C

**NOTE :** 1. Measured at 1MHz and Applied Reverse Voltage of 4.0 Volts.



**RATING AND CHARACTERISTIC CURVES RB200 THRU RB2010**

**FIG. 1-DERATING CURVE FOR OUTPUT RECTIFIED CURRENT**

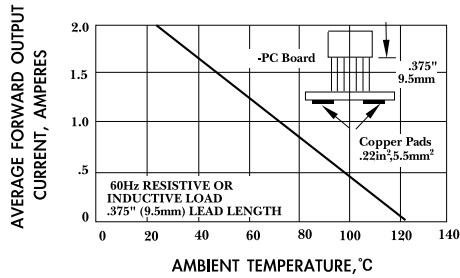

**FIG. 3-TYPICAL REVERSE CHARACTERISTICS**

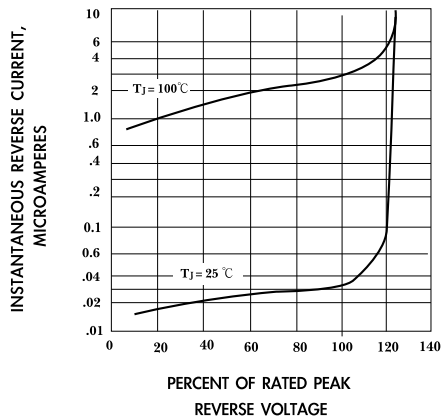

**FIG. 5-TYPICAL JUNCTION CAPACITANCE PER BRIDGE ELEMENT**

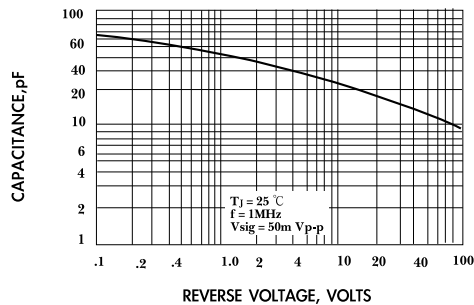

**FIG. 2-MAXIMUM NON-REPETITIVE PEAK FORWARD SURGE CURRENT**

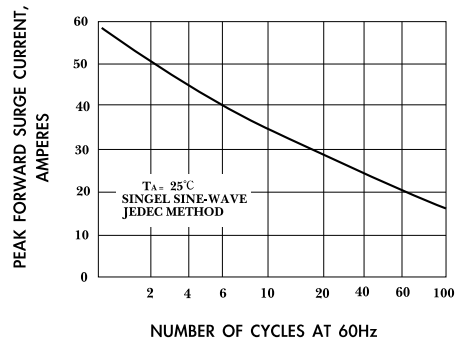

**FIG. 4-TYPICAL INSTANTANEOUS FORWARD CHARACTERISTICS**

